

NOTES:

1. SUBSTRATE: GERMANIUM (GE)
2. COATING
S1: NONE
S2: NONE
3. EDGES: DIAMOND TURNED
4. CENTERING: 3-5 arcmin
5. RoHS: COMPLIANT
6. ASPHERIC SURFACE DESCRIBED BY THE FOLLOWING EQUATION AND COEFFICIENTS SHOWN IN TABLE BELOW

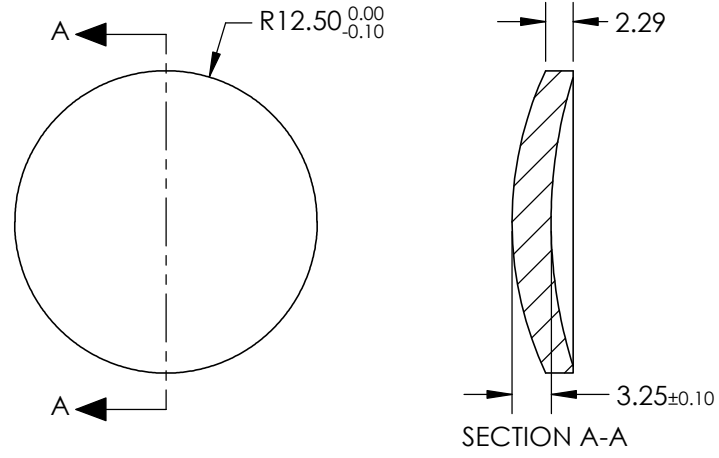

$$Z_{ASPH}(Y) = \frac{(\frac{1}{RADIUS}) * Y^2}{1 + \sqrt{1 - (1+k) * (\frac{1}{RADIUS})^2 * Y^2}} + D * Y^2 + E * Y^4 + F * Y^6 + G * Y^8 + H * Y^{10} + J * Y^{12} + L * Y^{14}$$

**FOR INFORMATION ONLY:
DO NOT MANUFACTURE
PARTS TO THIS DRAWING**

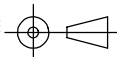

COEFFICIENT TABLE	
COEFFICIENT	S1
k	0.000000E+00
D	0.000000E+00
E	-3.9735336E-7
F	-6.3265251E-10
G	0.000000E+00
H	0.000000E+00
J	0.000000E+00
L	0.000000E+00

SPECIFICATIONS SUBJECT TO CHANGE WITHOUT NOTICE
DIMENSIONS ARE FOR REFERENCE ONLY

	S1	S2	EFL @ 4000nm: 30		 Edmund Optics®		
SHAPE	CONVEX	CONCAVE	BFL @ 4000nm: 27.52				
RADIUS	29.460	40.000			TITLE	25mm DIA X 30mm FL UNCOATED, GE ASPHERIC LENS	
SURFACE ACCURACY	0.3µm	N/A					
SURFACE QUALITY	60-40	60-40			DWG NO	68239	
CLEAR APERTURE	90%	90%					
BEVEL	PROTECTIVE AS NEEDED	PROTECTIVE AS NEEDED	ALL DIMS IN	mm			SHEET 1 OF 1