

NOTES:

**FOR INFORMATION ONLY:
DO NOT MANUFACTURE
PARTS TO THIS DRAWING**

1. SUBSTRATE:
N-BK7
2. SURFACE S2 TO BE PARALLEL TO SURFACE S1 TO WITHIN 1 ARCMIN
3. COATING (APPLY ACROSS COATING APERTURE)
S1: NONE
S2: NONE

4. EDGES: FINE GROUND

5. POWER, IRREGULARITY, AND SURFACE QUALITY SPECIFICATIONS APPLY ACROSS CLEAR APERTURE

6. TRANSMITTED WAVE FRONT OVER THE CLEAR APERTURE SHALL BE SPHERICAL (Y^4) -0.25λ WAVE PEAK TO VALLEY @ 587nm.
WAVE FRONT ERROR FROM IDEAL SPHERICAL FORM SHALL BE LESS THEN ±0.0625 WAVES

7. ASPHERIC SURFACE DESCRIBED BY (REF. COEFFICIENT TABLE):

$$Z(Y) = \frac{(RADIUS)^2 * Y^2}{1 + \sqrt{1 - (1+k) * (RADIUS)^2 * Y^2}} + D * Y^2 + E * Y^4 + F * Y^6 + G * Y^8 + H * Y^{10} + J * Y^{12} + L * Y^{14}$$

8. APPLY AN ARROW POINTING TOWARDS THE ASPHEREIC SURFACE S2 WITH PENCIL OR PERMANENT INK

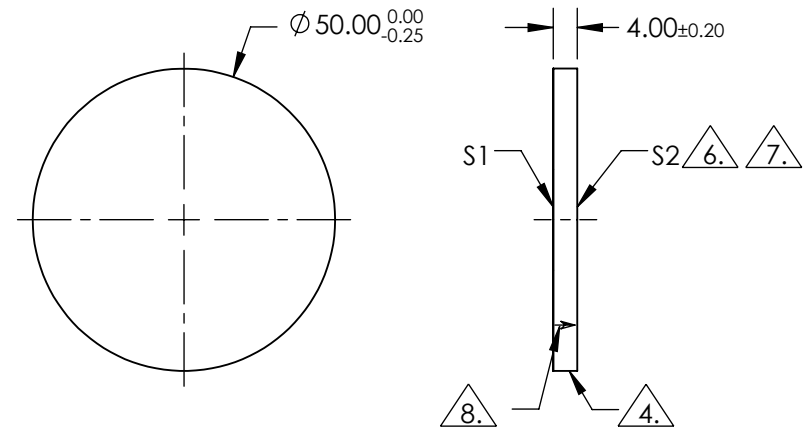
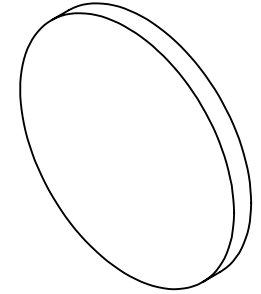

COEFFICIENT TABLE 7.

COEFFICIENT	S1	S2
k	0	0
D	0	0
E	0	1.109024E-09
G	0	0
H	0	0
J	0	0
L	0	0

SPECIFICATIONS SUBJECT TO CHANGE WITHOUT NOTICE
DIMENSIONS ARE FOR REFERENCE ONLY

Edmund Optics®

	S1	S2
SHAPE	PLANO	PLANO
CLEAR APERTURE	>85	>85
SURFACE QUALITY	60-40	60-40
BEVEL	PROTECTIVE AS NEEDED	PROTECTIVE AS NEEDED

THIRD ANGLE PROJECTION

ALL DIMS IN

mm

TITLE

50mm DIA -0.25λ ABERRATION, SPHERICAL
ABERRATION PLATE

DWG NO

66762

SHEET
1 OF 1