

NOTES:

1. SUBSTRATE:
FUSED SILICA
2. COATING (APPLY ACROSS COATING APERTURE)

S1 & S2: 266nm Laser AR Coating
R(ABS) < 0.25% @ 266nm @ 0° AOI

DAMAGE THRESHOLD,
PULSED: 3J/cm² @ 20ns, 20Hz @ 266nm

3. FINE GRIND SURFACE
4. POWER, IRREGULARITY, AND SURFACE QUALITY SPECIFICATIONS APPLY ACROSS CLEAR APERTURE
5. IMAGE ORIENTATION: BEAM DEVIATION
6. APPLY ARROW ON EDGE WITH PENCIL OR PERMANENT INK POINTING TOWARDS TITLED SURFACE S2
7. ROHS COMPLIANT

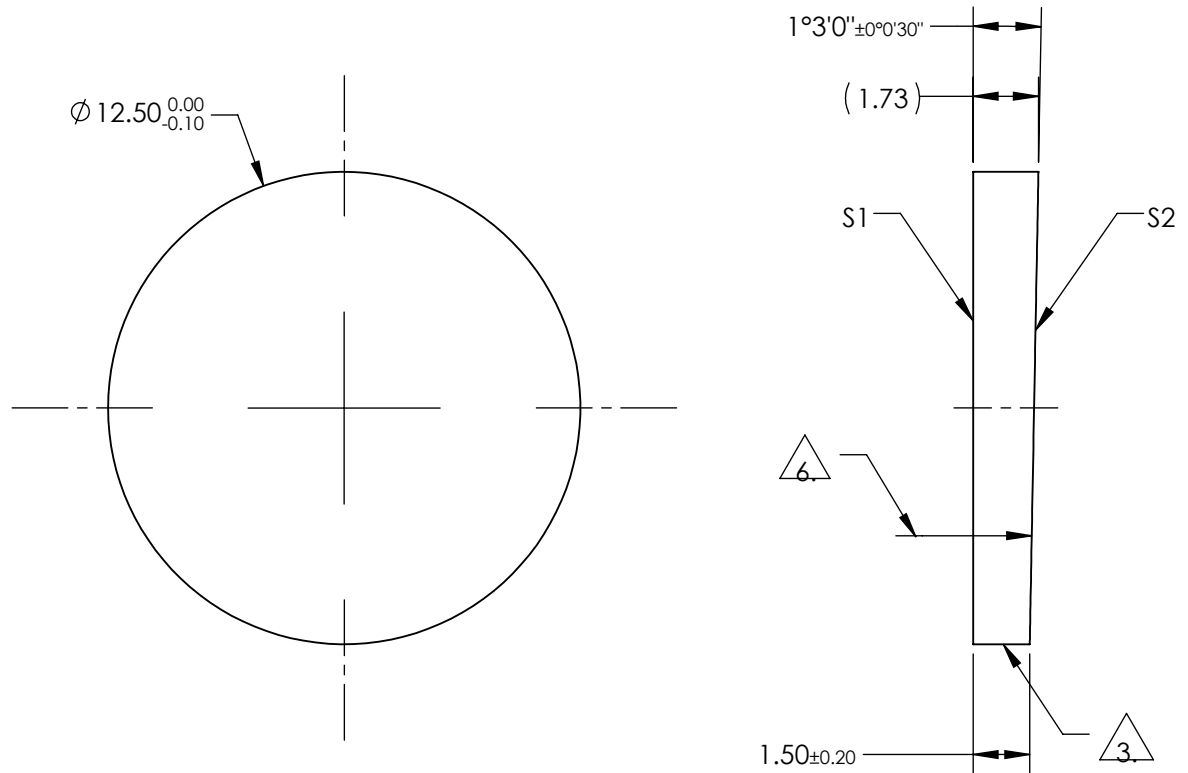

**FOR INFORMATION ONLY:
DO NOT MANUFACTURE
PARTS TO THIS DRAWING**

SPECIFICATIONS SUBJECT TO CHANGE WITHOUT NOTICE
DIMENSIONS ARE FOR REFERENCE ONLY

	S1	S2
SHAPE	PLANO	PLANO
SURFACE QUALITY	20-10	20-10
MIN CLEAR APERTURE	Ø11.25	Ø11.25
MIN COATING APERTURE	Ø11.25	Ø11.25
POWER AT 632.8nm	0.5 RINGS	0.5 RINGS
IRREGULARITY AT 632.8nm	0.2 RINGS	0.2 RINGS
BEVEL	PROTECTIVE AS NEEDED	PROTECTIVE AS NEEDED

EO® Edmund Optics®

THIRD ANGLE PROJECTION	TITLE	PRISM WEDGE FS 0.5 DEG 12.5mm 266nm	
ALL DIMS IN	mm	DWG NO	39057
			SHEET 1 OF 1